

finori GmbH
Straßäcker 2
D - 96253 Untersiemau

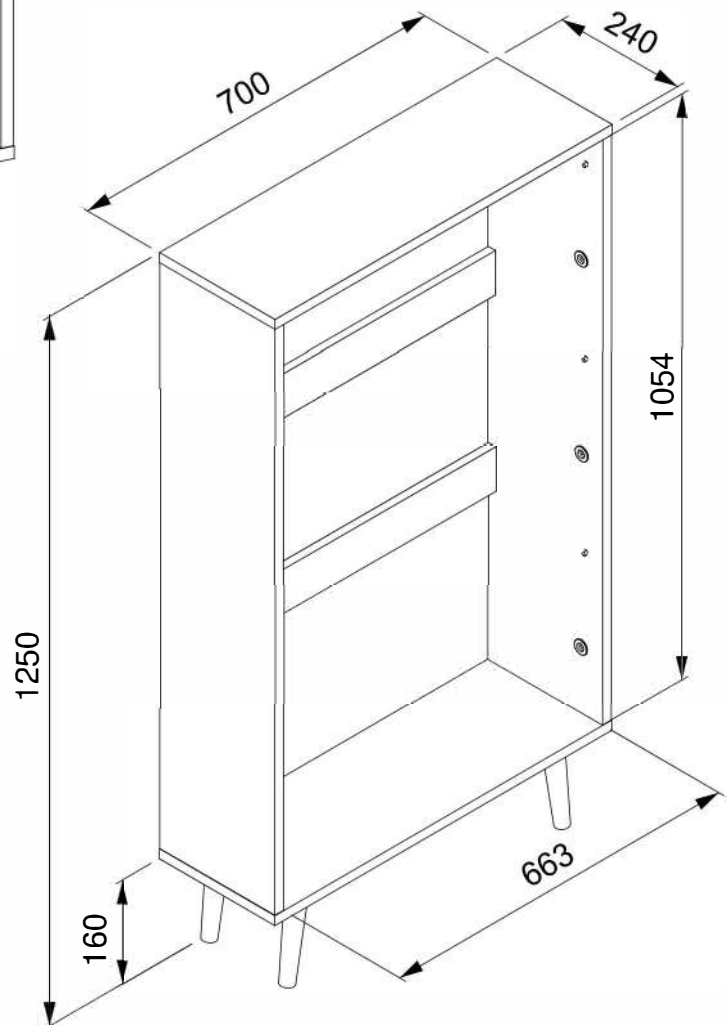

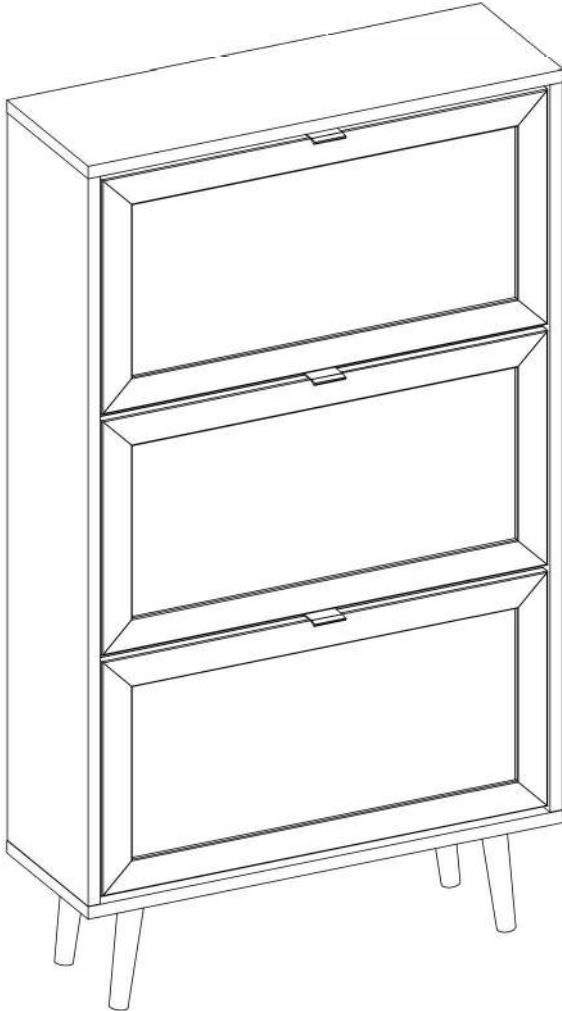

- (D) Befolgen Sie stets die Anleitung des Herstellers!
- (GB) Please generally follow the manufacturer's instructions!
- (FR) Suivez toujours les instructions du fabricant!
- (NL) Volg steeds de handleiding van de producent!
- (ES) Siga siempre las instrucciones del fabricante!
- (PL) Stale przestrzegaj instrukcji producenta!

- (RU) Всегда следуйте инструкции производителя!
- (IT) Seguire sempre le istruzioni del produttore!
- (HU) Mindig tartsa be a gyártó utasításait!
- (P) Siga sempre as instruções do fabricante!
- (CZ) Vždy dodržujte pokyny výrobce!



- (D) Verwenden Sie zur Reinigung nur ein feuchtes Tuch!
- (GB) Please only clean with a damp cloth!
- (FR) N'utilisez qu'un chiffon humide pour le nettoyage!
- (NL) Gebruik voor de reiniging enkel een vochtige doek!
- (ES) Para limpiar utilice sólo un paño húmedo!
- (PL) Do czyszczenia używaj wilgotnej szmatki!

- (RU) Для очистки используйте только влажную ткань!
- (IT) Per la pulizia, utilizzare solo un panno umido!
- (HU) A tisztításhoz elegendő egy nedves kendő használatát!
- (P) Para a limpeza use apenas um pano húmido!
- (CZ) Pro čištění používejte pouze vlhký hadřík!

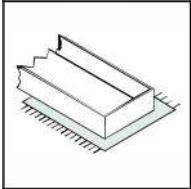

- (D) Bauen Sie das Produkt auf einer Unterlage auf!
- (GB) Please mount the product on a bottom support!
- (FR) Montez le produit sur une base!
- (NL) Monteer het product op een basis!
- (ES) Monte el producto sobre una base!
- (PL) Rozkładaj produkt na podkładce!

- (RU) Собирайте изделие на подстилке!
- (IT) Montare il prodotto su un supporto!
- (HU) Az összeszereléskor helyezzen a termék alá megfelelő alátétet!
- (P) Monte o produto numa superfície plana!
- (CZ) Výrobek smontujte na pevném podkladu!



- (D) Verwenden Sie das Produkt nur in Innenräumen!
- (GB) Please exclusively use the product indoors!
- (FR) N'utilisez le produit qu'à l'intérieur!
- (NL) Gebruik het product enkel binnenshuis!
- (ES) Utilice el producto sólo en interiores!
- (PL) Używaj produkt tylko w pomieszczeniach wewnętrznych!

- (RU) Используйте изделие только во внутренних помещениях!
- (IT) Utilizzare il prodotto solo in ambienti interni!
- (HU) A termék csak bel terekben használható!
- (P) Use o produto apenas no interior!
- (CZ) Používejte výrobek pouze uvnitř!

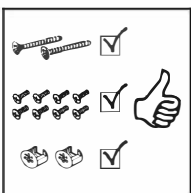

- (D) Legen Sie die Beschläge zusammen und prüfen Sie die Vollständigkeit!
- (GB) Please join the fittings and verify their completeness!
- (FR) Pliez les raccords ensemble et vérifiez qu'ils sont complets!
- (NL) Leg de onderdelen samen en controleer de volledigheid!
- (ES) Junte los accesorios y compruebe que están todos!
- (PL) Rozłóż poszczególne części i sprawdź kompletność!

- (RU) Положите фурнитуру в одно место и проверьте комплектность!
- (IT) Mettere insieme le guarnizioni e verificarne la completezza!
- (HU) Állítsa össze a sarokvasakat, és ellenőrizze, hogy épek-e!
- (P) Coloque os encaixes juntos e verifique se estão completos!
- (CZ) Složte armatury a zkontrolujte úplnost!



- (D) Bei fehlenden Teilen kontaktieren Sie den Hersteller!
- (GB) If parts are missing, please turn to the manufacturer!
- (FR) En cas de pièces manquantes, veuillez contacter le fabricant!
- (NL) Contacteer de fabrikant als er onderdelen ontbreken!
- (ES) En el caso de que falten piezas, póngase en contacto con el fabricante!
- (PL) W razie braku części skontaktuj się z producentem!

- (RU) При отсутствии каких-либо частей обратитесь к производителю!
- (IT) In caso di pezzi mancanti, contattare il produttore!
- (HU) Ha hiányozna valamelyik elem, lépjen kapcsolatba a gyártóval!
- (P) Em caso de peças em falta, entre em contato com o fabricante!
- (CZ) Pro chybějící díly kontaktujte výrobce!

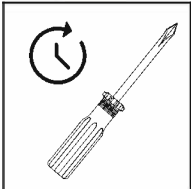

- (D) Ziehen Sie die Schrauben nach einiger Zeit des Gebrauchs erneut fest!
- (GB) Please re-tighten the screws after having used the product for a while!
- (FR) Resserrer les vis après un certain temps d'utilisation!
- (NL) Draai de schroeven na een zekere gebruikstijd opnieuw vast!
- (ES) Asegure de nuevo los tornillos tras usarlo durante un tiempo!
- (PL) Po pewnym czasie użytkowania ponownie dokręć śruby!

- (RU) Спустя некоторое время использования подкрутите гайки!
- (IT) Stringere nuovamente le viti dopo un certo periodo di utilizzo!
- (HU) A használat során némi idő elteltével húzza meg újra a csavarokat!
- (P) Reaperte os parafusos após algum tempo de uso!
- (CZ) Po určité době používání šrouby znovu utáhněte!



BOX 1

- f3 x 4
- b2 x 12
- c2 x 8
- d11 x 24
- e5 x 24
- da23 x 12

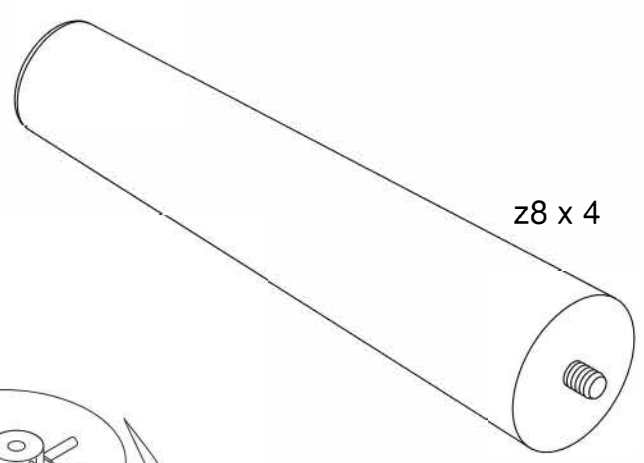
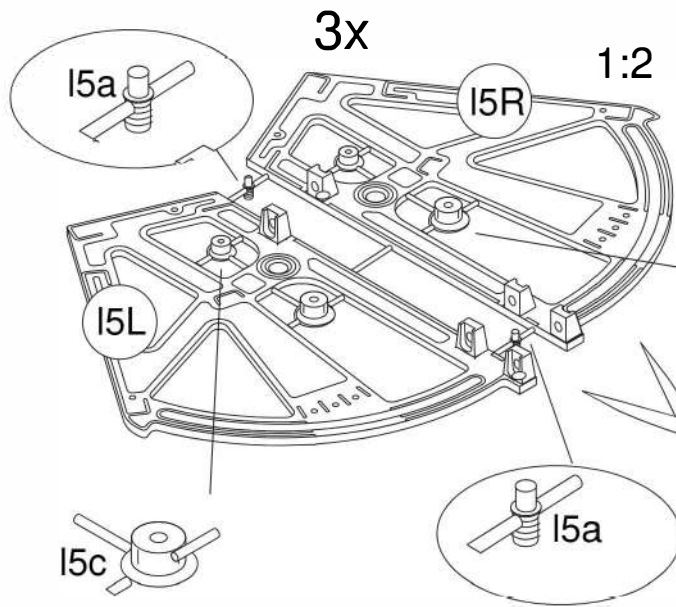
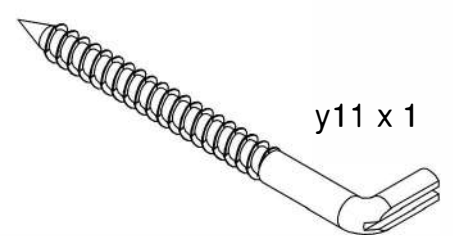
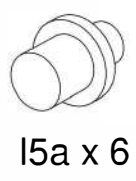
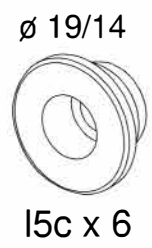
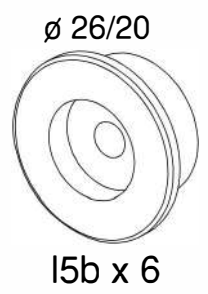
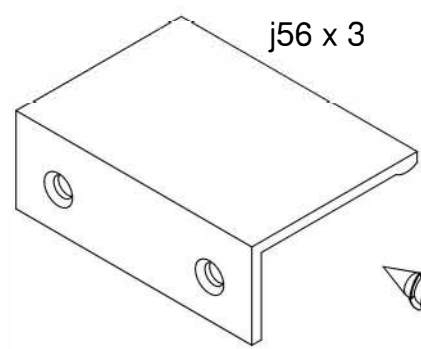
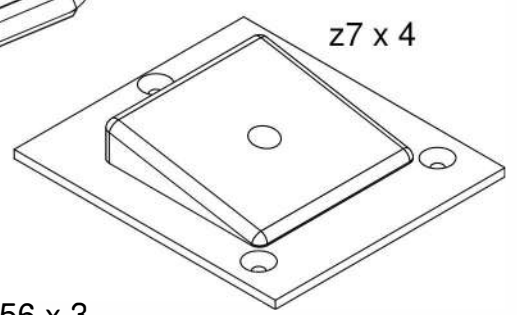
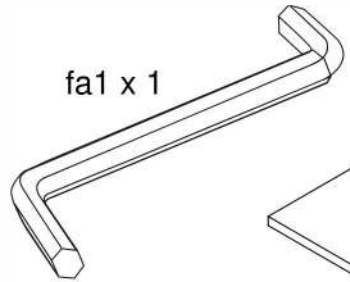
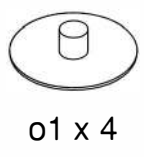

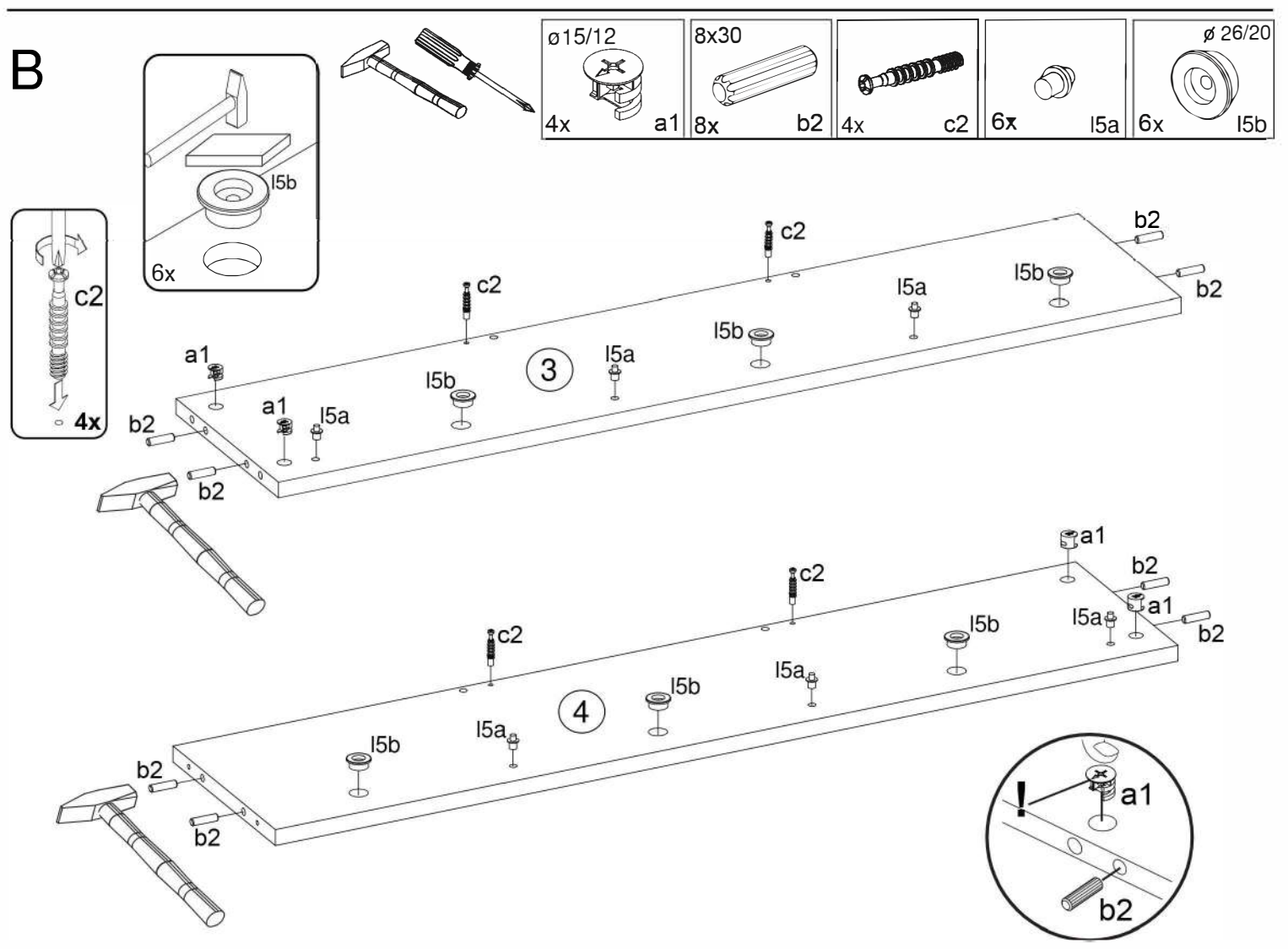
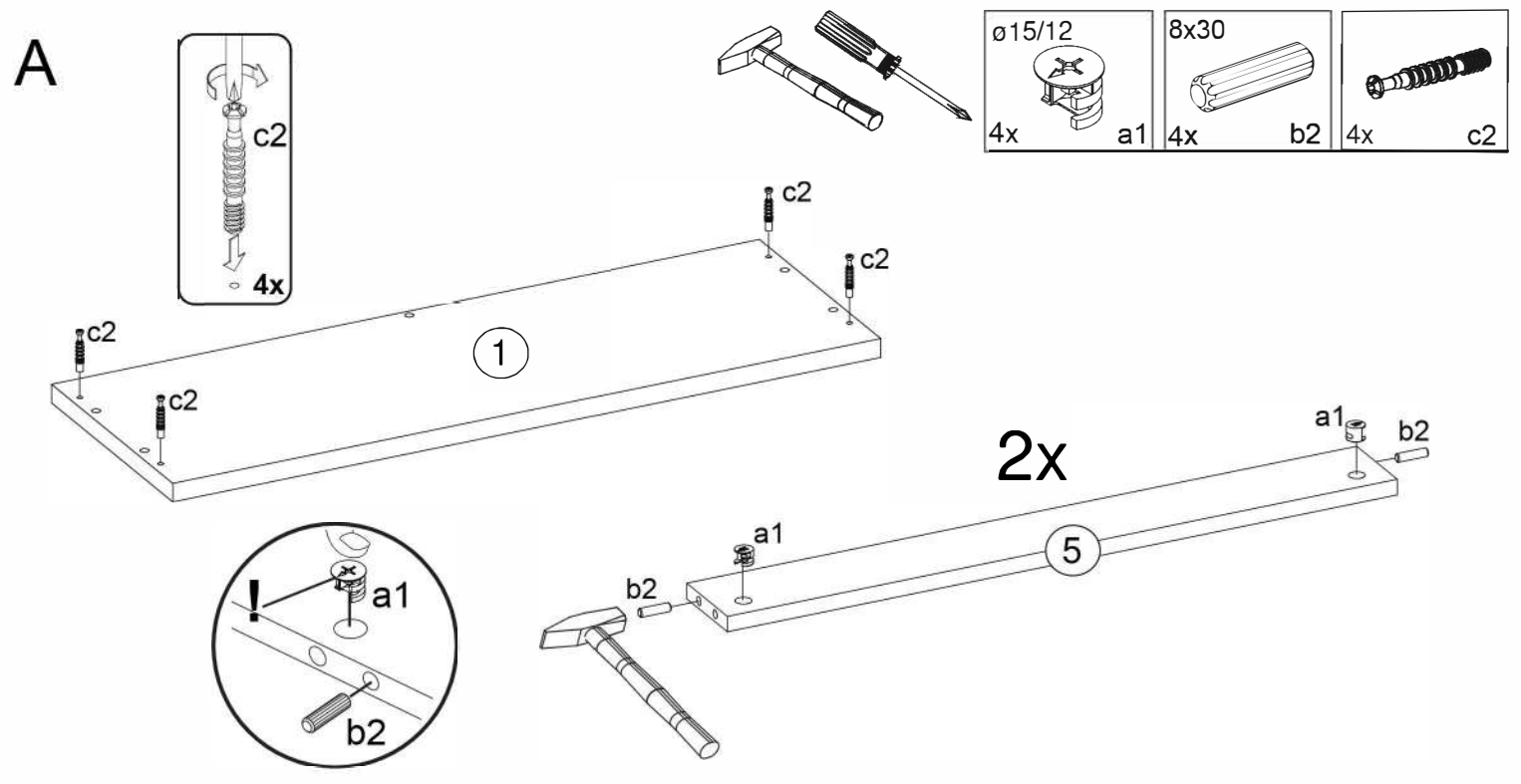

C

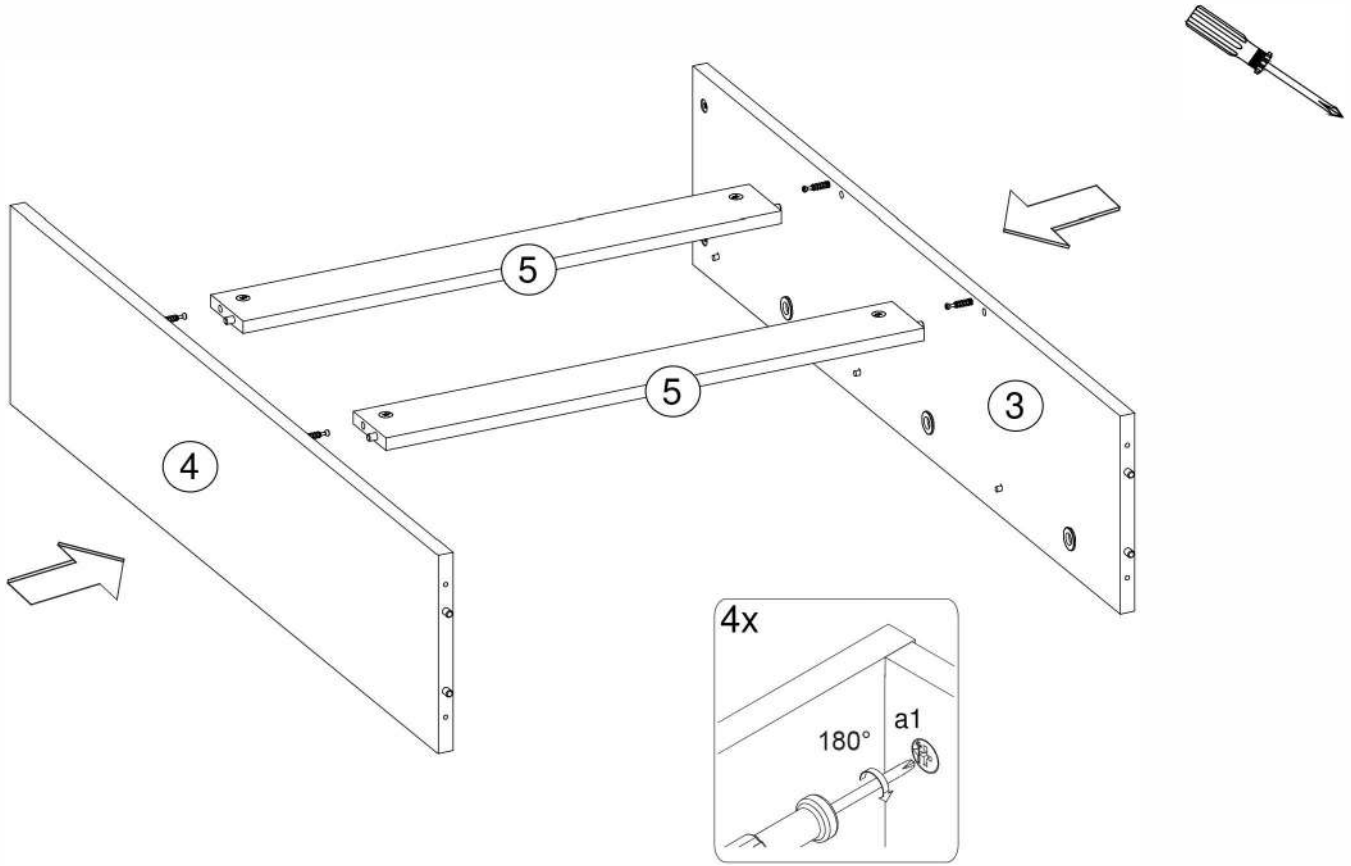

D

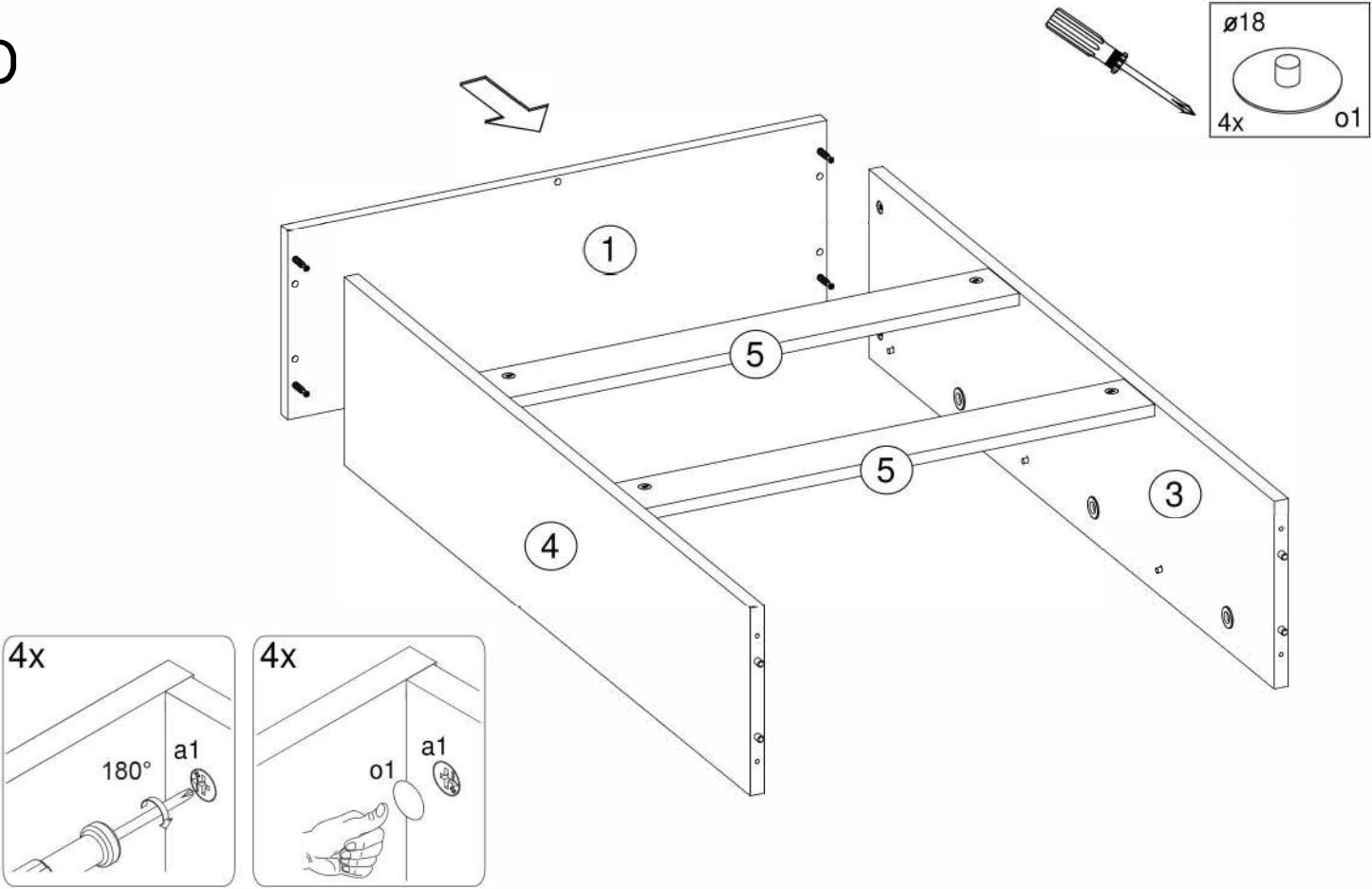

E

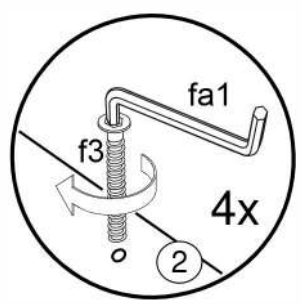
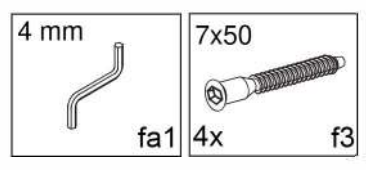
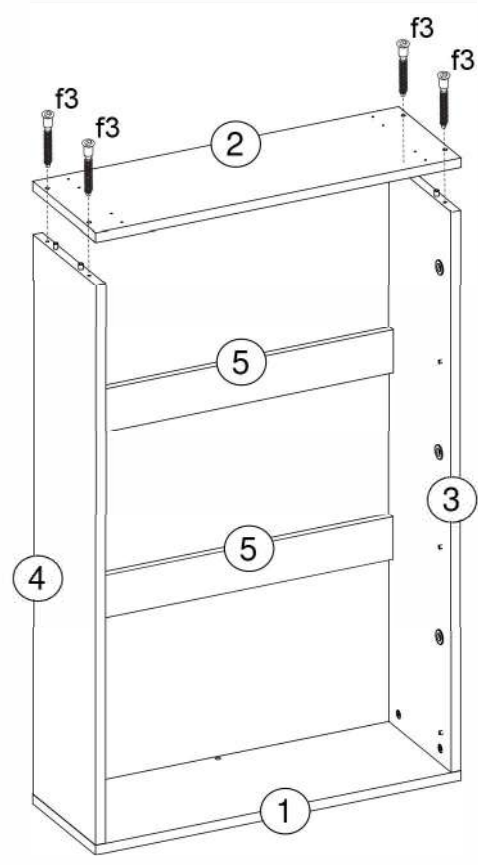

F

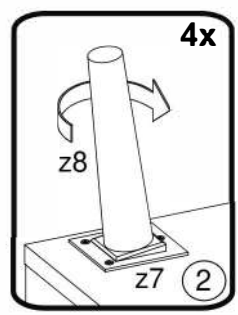
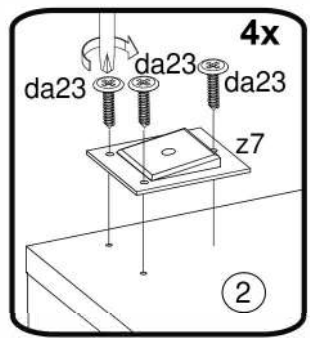
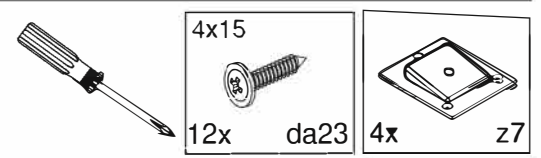
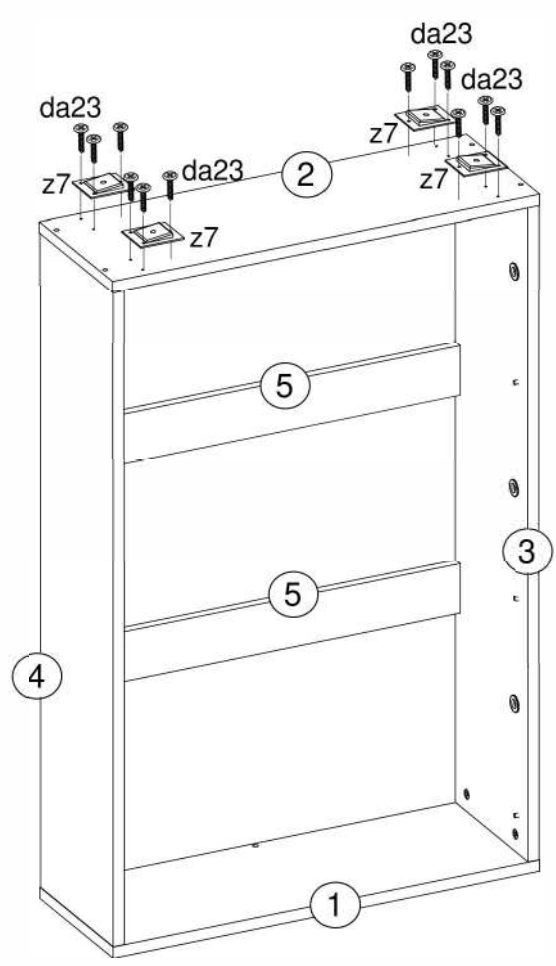

G Le meuble doit être fixé au mur!
 Das Möbel muss an der Wand befestigt werden!
 This unit must be secured to a wall using suitable fixing (not supplied)!

*Attention!
 Veuillez-vous informer sur le type de cheville et vis approprié à la nature de votre mur.
 *Achtung!
 informieren Sie sich vor der Wandmontage über das geeignete Montagematerial für ihre Wand!
 *Caution!
 Please inform yourself about mounting material suitable for your wall before mounting.

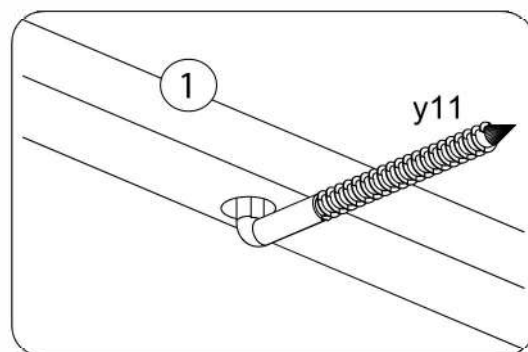
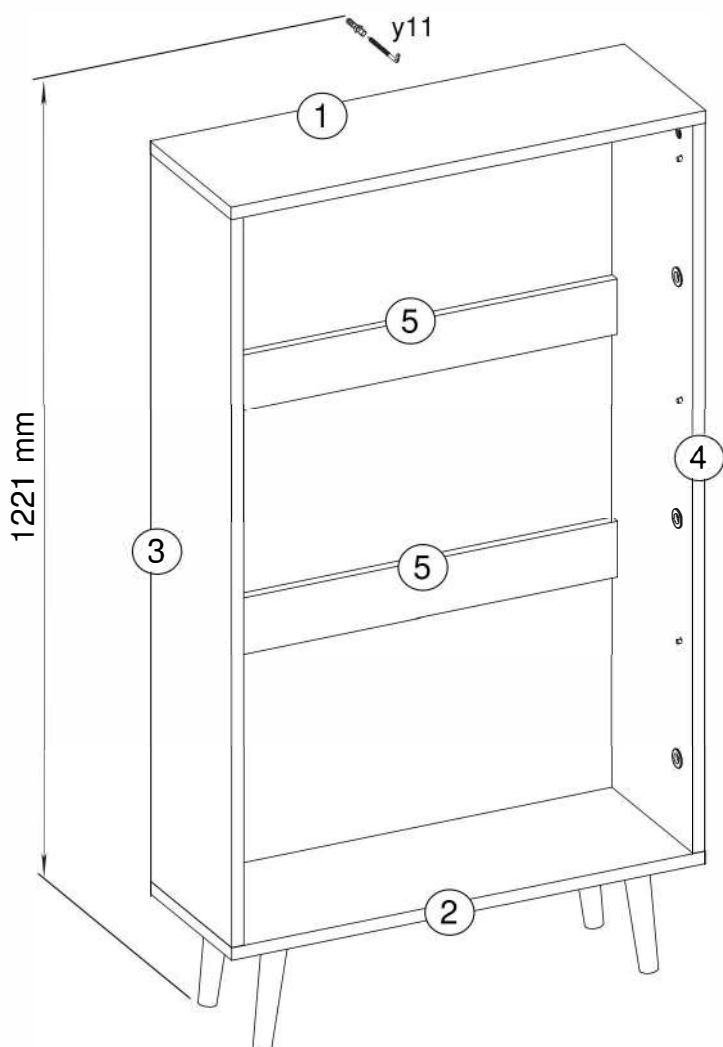
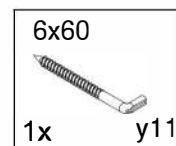

H

3x

| | | |
|----------------------|-------------------------|------------|
| 6 x 11 18x e5 | 3x I5L | 3x I5R |
| | 3,5 x 15 18x d11 | 3x j56 |

1)

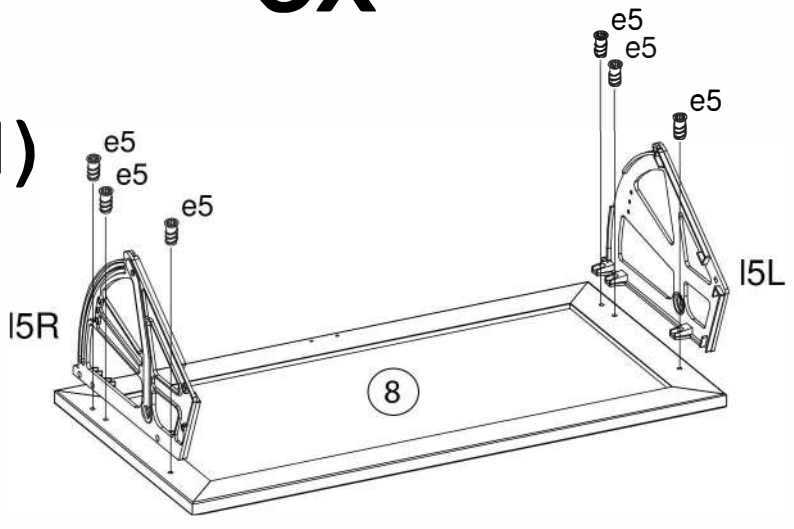

2)

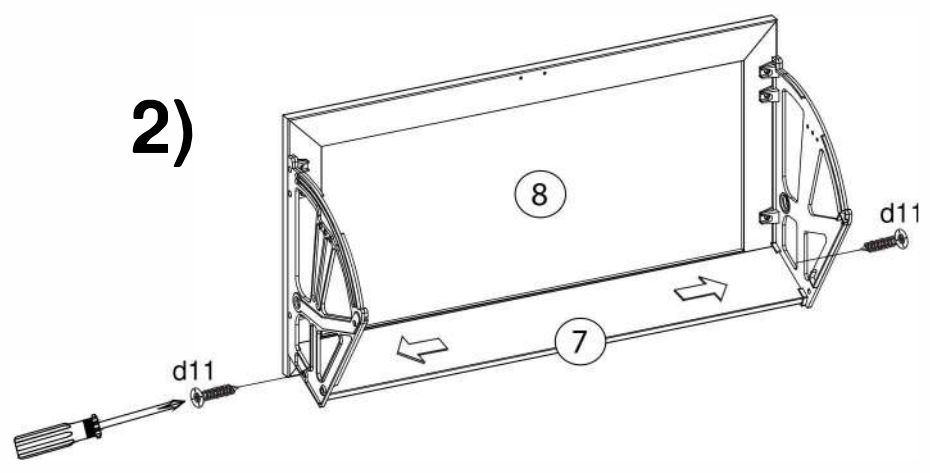

3)

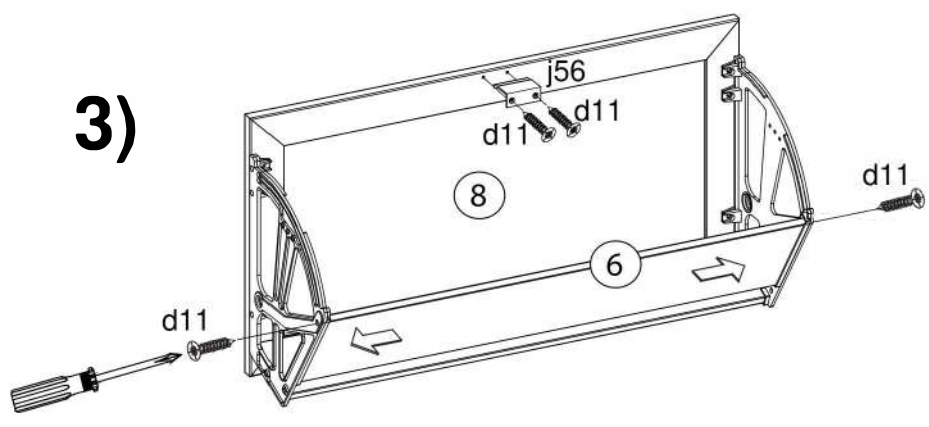

I



| | | |
|-----------------------|--------------------|----------------------|
| 3,5 x 15 6x d11 | 6 x 11 6x e5 | ∅ 19/14 6x I5c |
|-----------------------|--------------------|----------------------|

3x 1)

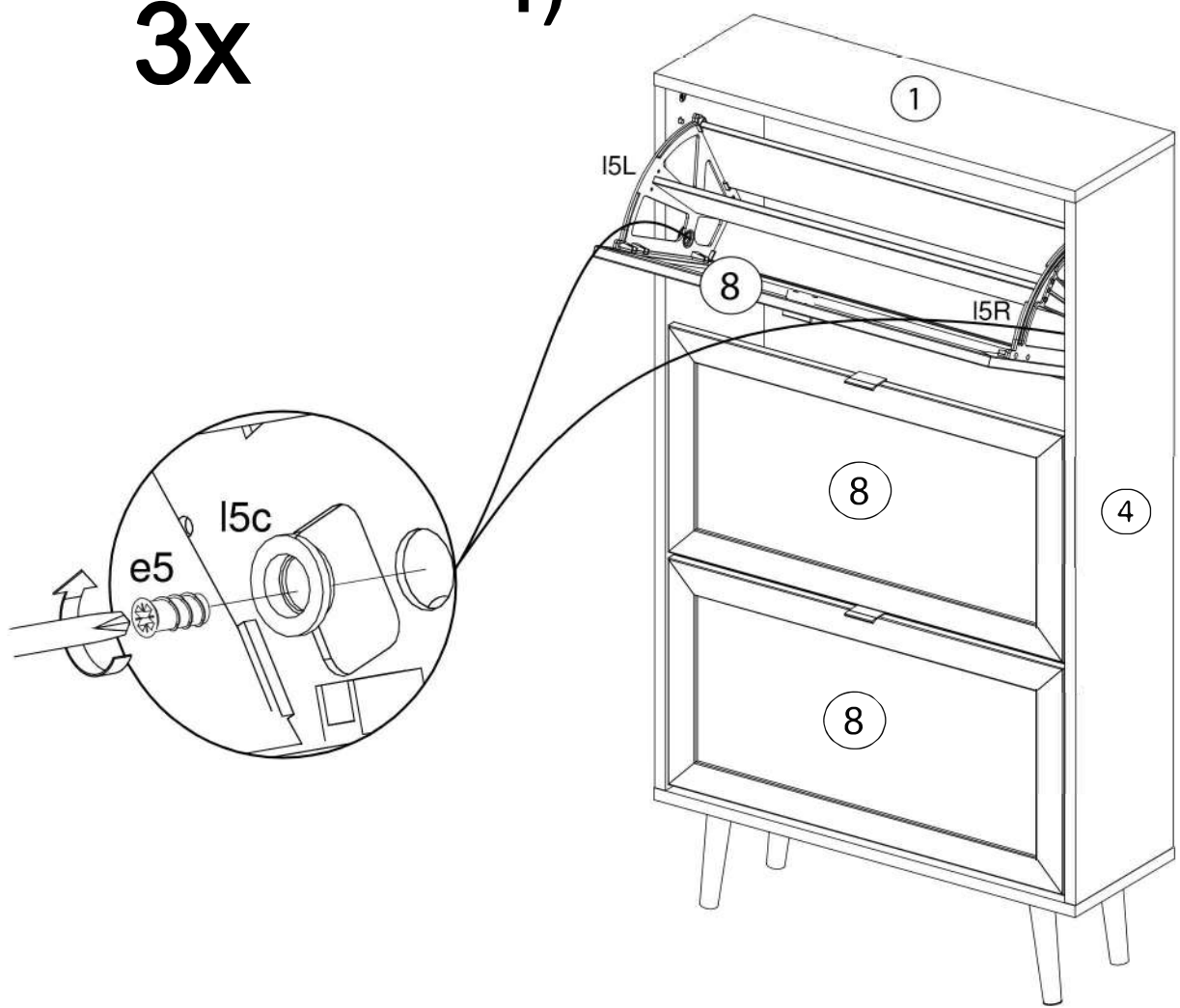

2)

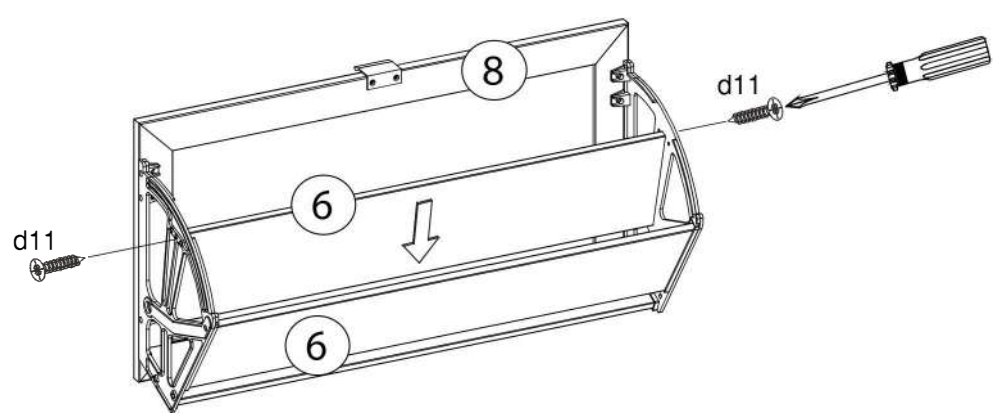



- Ⓓ Das Möbel muss an der Wand befestigt werden!
- ⒸⓅ Please ensure to mount the furniture to the wall!
- ⒻⓇ Les meubles doivent être fixés au mur!
- ⓃⓁ Het meubel moet aan de wand worden vastgemaakt!
- Ⓔ El mueble se tiene que fijar a la pared!
- ⓇⓁ Mebel należy przymocować do ściany!

- ⓇⓇ Мебель должна крепиться к стене!
- Ⓘ Il mobile deve essere fissato alla parete!
- ⓇⓇ A bútor a falon rögzítendő!
- Ⓟ O móvel tem que ser fixado na parede!
- ⒸⓇ Nábytek musí být připevněn ke stěně!



- Ⓓ Informieren Sie sich vor der Wandmontage über das geeignete Montagematerial!
- ⒸⓅ Please get informed on suitable assembly materials before commencing the wall-mounting!
- ⒻⓇ Renseignez-vous sur le matériel de montage approprié avant le montage mural!
- ⓃⓁ Informeer u voor de wandmontage over het geschikte montagematerieel!
- Ⓔ Infórmese antes del montaje en la pared del material apropiado de montaje!
- ⓇⓁ Przed montażem na ścianie upewnij się, jaki jest potrzebny właściwy materiał montażowy!

- ⓇⓇ Перед тем, как крепить мебель к стене, получите информацию о подходящем крепежном материале!
- Ⓘ Prima del fissaggio alla parete, informarsi sul materiale di montaggio adatto!
- ⓇⓇ A falra szerelés előtt tájékozódjon, hogy ehhez milyen szerelőanyagok szükségesek!
- Ⓟ Antes da montagem na parede, informe-se sobre o material de montagem adequado!
- ⒸⓇ Informujte se o vhodném montážním materiálu před montáží na stěnu!



- Ⓓ Beschaffen Sie sich das angemessene Material zur Wandbefestigung!
- ⒸⓅ Please obtain suitable wall-mounting materials!
- ⒻⓇ Procurez-vous le matériel approprié pour le montage mural!
- ⓃⓁ Verschaf u het adequate materieel voor de wandbevestiging!
- Ⓔ Procúrese el material adecuado para la fijación a la pared!
- ⓇⓁ Zakup odpowiedni materiał do przymocowania na ścianie!

- ⓇⓇ Приобретите соответствующий материал для крепления к стене!
- Ⓘ Procurarsi il materiale opportuno per il fissaggio alla parete!
- ⓇⓇ Szerezze be a falra szereléshez szükséges, megfelelő anyagokat!
- Ⓟ Obtenha o material adequado para a montagem na parede!
- ⒸⓇ Opatřte si vhodný materiál pro montáž na stěnu!



- Ⓓ Lassen Sie die Wandbefestigung von einer fachkundigen Person vornehmen!
- ⒸⓅ Ensure all wall-mounting is carried out by competent personnel!
- ⒻⓇ Faites effectuer le montage mural par une personne compétente!
- ⓃⓁ Laat de wandbevestiging door een professional uitvoeren!
- Ⓔ Deje que la fijación a la pared la haga un profesional!
- ⓇⓁ Zleć przymocowanie do ściany odpowiednio doświadczonej osobie!

- ⓇⓇ Поручите выполнение работ по креплению к стене специалисту!
- Ⓘ Far effettuare il fissaggio alla parete ad un esperto!
- ⓇⓇ A bútor falra rögzítését végeztesse ehhez értő személlyel!
- Ⓟ A montagem na parede deve ser executada por uma pessoa competente!
- ⒸⓇ Montáž na stěnu nechte provést odborně způsobilou osobou!

